

## Fully powered Logiflex Mini – light, flexible and safe!

Logiflex Mini is a light and maneuverable fully powered stacker – your best choice for the light handling in minor storage and shopping areas.

The design puts focus on the safety and ergonomic working conditions of the user. Logiflex Mini can be adjusted to the individual user, and the ergonomic correct handle ensures the user a relaxed hold. The low overall height gives optimum view conditions.

No damage to surroundings, pallets and goods – Logiflex has an elegant design with rounded corners.

High quality is ensured through an extended test program and in cooperation with experts in Health and Safety.



### Technical Specifications

Logiflex Mini gives the user

- easy setting of e.g. driving speed and acceleration
- compact construction
  - perfect in confined areas
- easy service
  - easy access to batteries
- low overall height – optimum view
- motor brake
- long operation time per charge



Possible to operate with the handle upright. Central location of all control buttons.



Hour counter, battery indicator and error finding in the same instrument.



Available with optional extras, e.g. crane arm, drum turner, boom, remote control and level control.

Product (measured in inch)	SELF MINI	SELF MINI	SELFS MINI	SELFS MINI
Capacity in lbs.	2200	2200	2200	2200
Lifting height with wrap-over forks $h_3$	36	65	35	63.75
Fork length $l$	42, 45		23.5/31.5/42/45/60*	
Overall height $h_1$	52	53	52	53
Overall width $b_1$	25, 28		6.5+ $b_4$	
Fork span $b_5$	Wrap-over: 22		Wrap-over: 13.25/31.5, chisel and bar: 9/27	
Length without forks $l_2$	24	24.75	24	24.75
Overall length with 45 forks $l_1$	71.85	72.25	71.85	72.25
Overall height $h_4$	52	79.75	52	78.5
Lowered height, forks $h_{13}$	3.5		Wrap-over: 2.5, chisel: 1.75, bar: 2.5	
Load centre $c$	1/2			
Width between legs $b_4$	33.5-37, 37-44.25, 44.25-51.5, 49-56**			
Fork width $e$	6.5			
Run-in length $l_x$	43 with 45" forks		42.5 with 45" forks	
Gangway (w/pallet: 47 x 31.5) $A_{st}$	86.5 - tests show that 67" are enough - depends on $b_4$			
Free lift $h_2$			13	13
Turning angle of the wheels	210°			
Motor	0,7 kW 24 V speed control electronically variable			
Driving speed with/without load	Below 19.5" lift: 5,2/5,5 km/h, over 19.5" lift: 3/4 km/h			
Pump motor	1,2 kW 24 V			
Lifting speed with/without load	2.75"/4.75" per sec.			
Lowering speed with/without load	4.75"/2.75" per sec.			
Weight in lbs (without battery)	679	799	766	887

\* Reduced capacity 1650 lbs.

\*\* Width between straddle legs of more than 51.5": Max. capacity 1760 lbs. Fork length of 60" is not recommended.



For intensive use, we recommend SELF or SELFS.

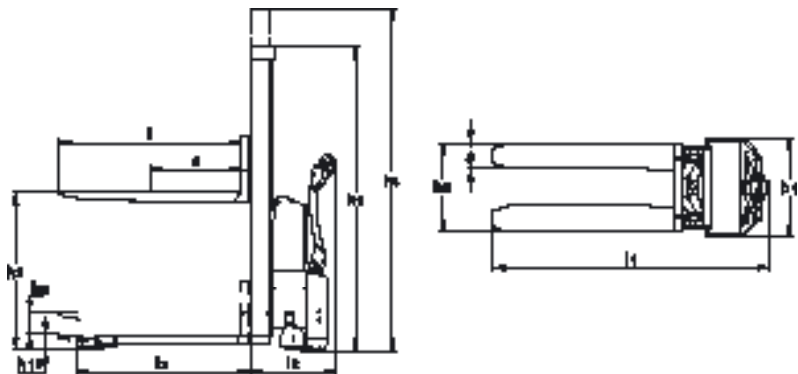

We also offer tailor-made solutions.

Please ask for further information or visit our website [www.interthor.com](http://www.interthor.com)