

## **Boom - when carrying reels**

High flexibility and efficiency - the boom makes it easy to carry reels in horizontal position.

The boom with a quick shift system can easily and quickly be fitted on all Trans-Positioners and Trans-Stackers with an adjustable carriage. Furthermore the boom can easily be replaced by one of the many Interthor fork options.

A wide range of optional extras ensures an optimum utilization of the Trans-Positioner and Trans-Stacker - the same unit can be fitted with crane arm, platform, drum turner, reel spindle and reel clamp.

High quality is ensured through an extended test program and in cooperation with experts in Health and Safety.



**Technical Specifications**

The boom can handle horizontal reels.

The boom has a quick shift system and is therefore easy and quick to fit on all Trans-Positioners and Trans-Stackers with adjustable carriage.

The capacity depends on weight and length of the reel. The load is to be placed equally on the boom length.

The load centre of the reel has to be placed behind the load wheel centre on the legs (safety precaution).

Strong construction ensures a long operating life and low maintenance costs.

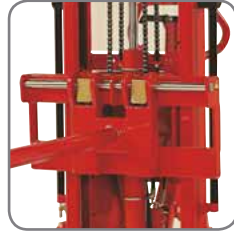

Quick shift makes it easy to replace the boom by other optional extras or forks.



The lifting/lowering function of the electric TP and TS models can be operated by remote control (optional extra).



When using a TP or TS without straddle legs, the reel to be handled has to be placed on a pallet.

Product (measured in inch)	TP-MM, TP-ME, TP-EE, TS-MM, TS-ME, TS-EE	TPS-MM, TPS-ME, TPS-EE, TSS-MM, TSS-ME, TSS-EE	TP-MM, TP-ME, TP-EE, TS-MM, TS-ME, TS-EE	TPS-MM, TPS-ME, TPS-EE, TSS-MM, TSS-ME, TSS-EE		
Run-in lengths $l_x$	31.75	32.25	43.5	42		
Lifting height, boom $h_3$	$h_{13}$ + lifting height (Trans-Positioner & Trans-Stacker)					
Lowered height, boom $h_{13}$	6.7 (without load)					
Length of boom $l$	31.5		45			
Diameter of boom $D$	1.5	2	2.75	1.5	2	2.75
Capacity (kg)	330	650	1000	230	430	800



The Reel Rotator - an ideal alternative when lifting and turning reels.

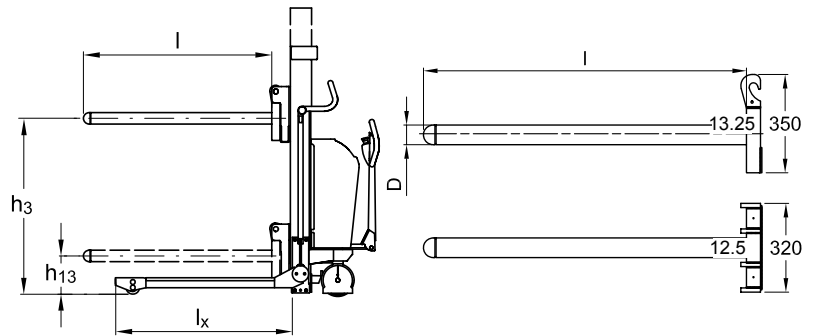

A straddle Trans-Stacker handles reels from a stock to a lorry.



The boom in the packaging industry.



Optional extras, e.g. platform, reel spindle and drum turner.



The boom in a stock area.

*We also offer tailor-made solutions. Please ask for further information or visit [www.interthor.com](http://www.interthor.com)*